

Portable Air Conditioner WDH-AC016



Dear Customer,

you have chosen a high-quality product. To ensure that you enjoy this product for many years to come, here are a few tips:

After transport:

As the unit uses refrigerant, it may sometimes be transported improperly despite the careful instructions on the packaging. We therefore ask you to leave it standing upright for at least 6 hours before using it for the first time so that the refrigerant in the unit can settle again.

In case of any problems:

We hope that the device meets your expectations! If, despite the utmost care, you have cause for complaint, please contact us as we are very keen to ensure your satisfaction and would like to clear up any misunderstandings.

Important safety instructions:

- Only operate the device in an upright position and on an upright/level surface (Fig. 1)! If the device has been tilted at a 45° angle, allow it to stand upright for 24 hours before use.
- Ensure that no moisture gets into or onto the device (Fig. 2)!
- Ensure a minimum distance of approx. 50 cm from furniture and walls (Fig. 3)!
- Be careful with electricity; never insert objects into the device (Fig. 4)!
- The device is filled with the flammable refrigerant R290, so strictly follow the instructions in this operating manual and read it in its entirety.
- Do not attempt to repair the appliance yourself!
- Do not place any objects on the appliance and ensure that the air intake and exhaust are always unobstructed!
- Do not operate the device in close proximity to walls, curtains, or other objects that could block the air inlet or outlet. Always keep the inlet and outlet free of obstacles.
- Supervise the air conditioner when children or animals are near the device!
- This air conditioner should only be operated by persons who have the physical and mental abilities necessary to operate this device without problems/failings!
- This air conditioner is only approved for indoor use!
- Only qualified personnel or electricians are permitted to open the unit!
- Only use the recommended voltage to operate the device!
- Ensure that the power cable is uncoiled (untangled) before connecting it to the power outlet!
- Please do not use the power cord as a pull cord for the air conditioner!
- Before starting up the unit, make sure that the plug is clean and properly connected to the power outlet!
- Never touch the plug or power outlet with wet hands!
- Ensure that there are no highly flammable or explosive substances (e.g., gases/oils, etc.) near the unit!
- If you are not using the unit for a long period of time, switch it off and unplug it!

Please switch off the device immediately and disconnect it from the power supply if something seems to be wrong! In this case, please contact a specialist and do not attempt to repair the device yourself!

Examples: Fan does not run during operation, fuse has blown, or compressor is rattling loudly.



Fig. 1



Fig. 2



Fig. 3

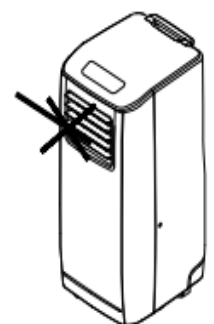

Fig. 4

This device contains parts that must not be replaced or repaired!

The refrigerant cannot be renewed or replaced!

Do not carry out any repairs or modifications to your device yourself!

Maintenance and repair work that requires the assistance of other qualified persons must be carried out under the supervision of specialists in the use of flammable refrigerants.

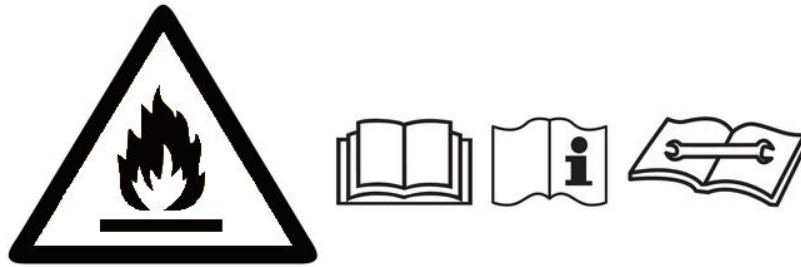

Important safety instructions for repairing a device with R290 refrigerant:

1. Check the environment

Before you start working on systems containing flammable refrigerants, safety checks are required to ensure that the risk of ignition is minimized. When repairing the refrigerant system, the following safety precautions must be observed and complied with before work is carried out on the system.

Procedure

The work must be carried out under a controlled procedure to minimize the risk of flammable gases or vapors being present during the work.

2. General work area

All maintenance personnel and other persons in the vicinity must be instructed on the nature of the work to be performed. Work in confined spaces must be avoided. The area around the work area must be cordoned off. Ensure that the conditions in the work area have been made safe by checking for flammable materials.

3. Checking for the presence of refrigerants

The area must be checked with a suitable refrigerant detector before and during work to ensure that the technician is aware of the potentially flammable atmosphere. Ensure that the refrigerant detector used is suitable for working with flammable refrigerants, e.g. non-sparking, adequately sealed, and intrinsically safe.

4. Availability of a fire extinguisher

If hot work is to be carried out on refrigerant equipment or associated parts, suitable fire extinguishing equipment must be readily available. Ensure that a dry powder fire extinguisher or CO₂ fire extinguisher is nearby.

5. No ignition sources

Persons performing work related to a refrigerant system that involves exposure to piping containing or having contained flammable refrigerants must use ignition sources in such a way that they do not pose a fire or explosion hazard. All possible ignition sources, including smoking cigarettes, should be kept sufficiently far away from the installation, repair, and disposal site, during which the flammable refrigerant may be released into the surrounding area. Before work begins, the area around the equipment must be inspected to ensure that there are no flammable hazards or ignition risks. "No smoking" signs must be posted.

6. Ventilated area

Ensure that the work area is outdoors or that it is adequately ventilated before working on the system or performing hot work. Adequate ventilation must be ensured throughout the entire duration of the work to be performed. Ventilation should safely disperse any refrigerant that is released and preferably expel it externally into the atmosphere.

7. Checking the refrigerant equipment

When replacing electrical components, they must be suitable for the purpose and have the correct specifications. The manufacturer's guidelines for maintenance and repair must be observed and followed at all times. If in doubt, contact the manufacturer's technical department for assistance. The following checks must be carried out on installations containing flammable refrigerants:

- The filling quantity must be in accordance with the size of the room in which the parts containing refrigerant are installed.
- The ventilation equipment and ventilation outlets are functioning properly and are not blocked.

8. Inspection of electrical equipment

Before repairing and maintaining electrical components, preliminary safety tests and inspections must be carried out on the components. If there is a defect that could compromise safety, the device may only be connected to the power supply once the defect has been rectified. If the defect cannot be rectified immediately but operation must continue, an adequate temporary solution must be found. This must be reported to the owner of the equipment so that all parties are informed.

The initial safety checks must include:

- Capacitors must be discharged; this should be done in a safe manner to avoid the possibility of sparking.
- No live components or wiring should be exposed when filling, restoring, or flushing the system. Continuity of the ground connection.

9. Repairs to hermetically sealed components

During the repair of hermetically sealed components, the entire power supply to the device must be disconnected before removing sealed covers, etc. If it is absolutely necessary for the device to be powered during maintenance, a permanent leak detection system must be in place to warn of a potentially dangerous situation.

Particular attention must be paid to the following point to ensure that when working on electrical components, the enclosure is not modified in such a way that the degree of protection is compromised. This includes damage to cables, an excessive number of connections, connection terminals that do not comply with the original specification, damage to seals, improper attachment of sealing screws, etc.

Ensure that the device is securely mounted.

Ensure that seals or sealing materials are not worn to the point where they no longer serve their purpose of preventing the ingress of flammable atmospheres. Replacement parts must comply with the manufacturer's specifications.

NOTE: The use of silicone sealants may interfere with the effectiveness of some leak detectors. Intrinsically safe components do not need to be sealed before working on them.

10. Repair of intrinsically safe components

Do not apply a permanent inductive or capacitive load to the circuit without ensuring that it does not exceed the permissible voltage and current for the equipment used. Intrinsically safe components are the only types that can be worked on while connected to the power supply in the presence of a flammable atmosphere. The test device must have the correct ratings. Only replace components with parts specified by the manufacturer. Other parts may cause a leak that could ignite the refrigerant in the atmosphere.

11. Wiring

Check that the wiring is not subject to wear, corrosion, excessive pressure, vibration, sharp edges, or other harmful environmental effects. The test must also take into account the effects of aging or continuous vibration from sources such as compressors or fans.

12. Detection of flammable refrigerants

Under no circumstances should potential ignition sources be used when searching for or detecting refrigerant leaks. A halogen search lamp (or any other search device that uses open flames) must not be used.

13. Leak detection methods

The following leak detection methods are considered acceptable for systems containing flammable refrigerants.

Electronic leak detectors must be used to detect flammable refrigerants, but their sensitivity may not be sufficient or they may need to be recalibrated. (Detection equipment must be calibrated in a refrigerant-free area.) Ensure that the leak detector is not a potential ignition source and that it is suitable for the refrigerant used. Leak detection equipment must be set to a percentage of the lower explosive limit and must be calibrated for the refrigerant used, and the appropriate percentage of gas (25% maximum) must be confirmed.

Leak detection fluids are suitable for use with most refrigerants, but the use of cleaning agents containing chlorine must be avoided, as chlorine can react with the refrigerant and corrode copper piping.

If a leak is suspected, all naked flames must be removed/extinguished.

If a refrigerant leak is detected that requires soldering, all refrigerant must be recovered from the refrigeration system or isolated (by closing valves) in a part of the system away from the leak.

Oxygen-free nitrogen must then be flushed through the system before and during the soldering process.

14. Removal and drainage

When you intervene in the refrigerant circuit to carry out repairs - or for other reasons - conventional methods must be used. However, it is important that proven procedures are always followed, as flammability must be taken into account. The following procedure should be followed:

- Remove the refrigerant
- Flush the circuit with inert gas
- Evacuate the air
- Flush again with inert gas
- Open the circuit by cutting or soldering

The refrigerant charge must be prepared in the correct preparation cylinders. The system must be "flushed" with oxygen-free nitrogen to keep the device safe. This process may need to be repeated several times. Compressed air or oxygen must not be used for this purpose.

Flushing can be achieved by introducing oxygen-free nitrogen into the vacuum in the system and continuing to fill until the working pressure is reached, then venting to atmosphere and finally drawing a vacuum. This process must be repeated until there is no refrigerant left in the system.

When the final filling with oxygen-free nitrogen is complete, the system must be vented to atmospheric pressure. This is absolutely necessary if soldering work has to be carried out on the piping. Ensure that the outlet for the vacuum pump is not located near sources of ignition and that ventilation is provided.

15. Filling process

In addition to conventional filling procedures, the following requirements must be observed:

- Ensure that there is no contamination of the various refrigerants when filling the equipment. Hoses or cables must be as short as possible to minimize the amount of refrigerant contained therein.
- Cylinders must remain upright.
- Ensure that the cooling system is grounded before filling the system with refrigerant.
- Mark the system when filling is complete (if not already done).
- Extreme care must be taken not to overfill the refrigeration system.
- Before refilling the system, the pressure must be tested with oxygen-free nitrogen. The system must be tested for leaks at the end of filling but before commissioning. A check leak test must be performed before leaving the site.

16. Decommissioning

Before performing this procedure, it is necessary that the technician is fully familiar with the equipment and its details. It is a recommended standard that all refrigerants are safely recycled. Before the task is performed, an oil and refrigerant sample must be taken if analysis is required before the recovered refrigerant can be reused. It is necessary that electrical power is available before the task is started.

- a) Familiarize yourself with the equipment and its operation.
- b) Disconnect the system from the power supply.
- c) Before performing the procedure, make sure that
 - that mechanical handling devices are available, if necessary also for handling refrigerant cylinders;
 - that personal protective equipment is available and worn properly;
 - that the reconditioning process is supervised by a competent person at all times;
 - that the reconditioning equipment and cylinders comply with the applicable standards.
- d) If possible, pump out the refrigerant system.
- e) If a vacuum is not possible, create a collection line so that the refrigerant can be removed from the various parts of the system.
- f) Make sure that the cylinder is on the scales.
- g) Start the recovery unit and operate it according to the manufacturer's instructions.
- h) Do not overfill the cylinders (no more than 80% of the liquid filling capacity).
- i) Do not exceed the maximum working pressure of the cylinder, even temporarily.
- j) Once the cylinders have been filled correctly and the process is complete, ensure that the cylinders and equipment are removed from the site immediately and that all shut-off valves on the equipment are closed.
- k) Recycled refrigerant must not be filled into other refrigeration systems unless it has been cleaned and tested.

17. Labeling

The equipment must be labeled to indicate that it has been taken out of service and that the refrigerant has been drained. The label must be dated and signed. Ensure that labels are affixed to the equipment indicating that it contains flammable refrigerant.

18. Recycling

When removing refrigerant from a system, either for maintenance or decommissioning, it is recommended standard practice that all refrigerant be safely removed. When transferring refrigerant to cylinders, ensure that only suitable refrigerant recycling cylinders are used. Ensure that the correct number of cylinders is available to hold the entire quantity of refrigerant. All cylinders used must be suitable and marked for recycled refrigerant (i.e. special cylinders for recycling refrigerant). The cylinders must have a pressure relief valve and a connected shut-off valve and be in good working order. Empty recycling cylinders must be evacuated and, if possible, cooled before recycling.

The recycling equipment must be in good working order with appropriate instructions for the equipment in question and must be suitable for recycling flammable refrigerants. In addition, a set of calibrated scales in good working order must be available. Hoses must be complete with leak-free and undamaged disconnect couplings. Before using the recycling equipment, check that it is in good working order, that it has been properly maintained, and that all associated electrical components are sealed to prevent ignition in the event of refrigerant release. If in doubt, contact the manufacturer.

The reclaimed refrigerant must be returned to the refrigerant supplier in the correct processing cylinder, and the appropriate disposal certificate must be arranged. Do not mix refrigerants in reclaim units, especially in cylinders.

If a compressor or compressor oils are to be removed, ensure that they have been evacuated to an acceptable level to ensure that no flammable refrigerant remains in the lubricant. The evacuation process must be carried out before returning the compressor to the supplier. To speed up this process, only the electric heating of the compressor housing may be used. When draining oil from a system, this must be done in a safe manner.

19. Electrical components

Electrical components that can generate arcs or sparks and that are not considered ignition sources due to compliance with 22.116.1 letters b), c), d) or f) may only be replaced with parts specified by the equipment manufacturer. Replacement with other parts may result in ignition of the refrigerant in the event of a leak.

Description of appliance parts:

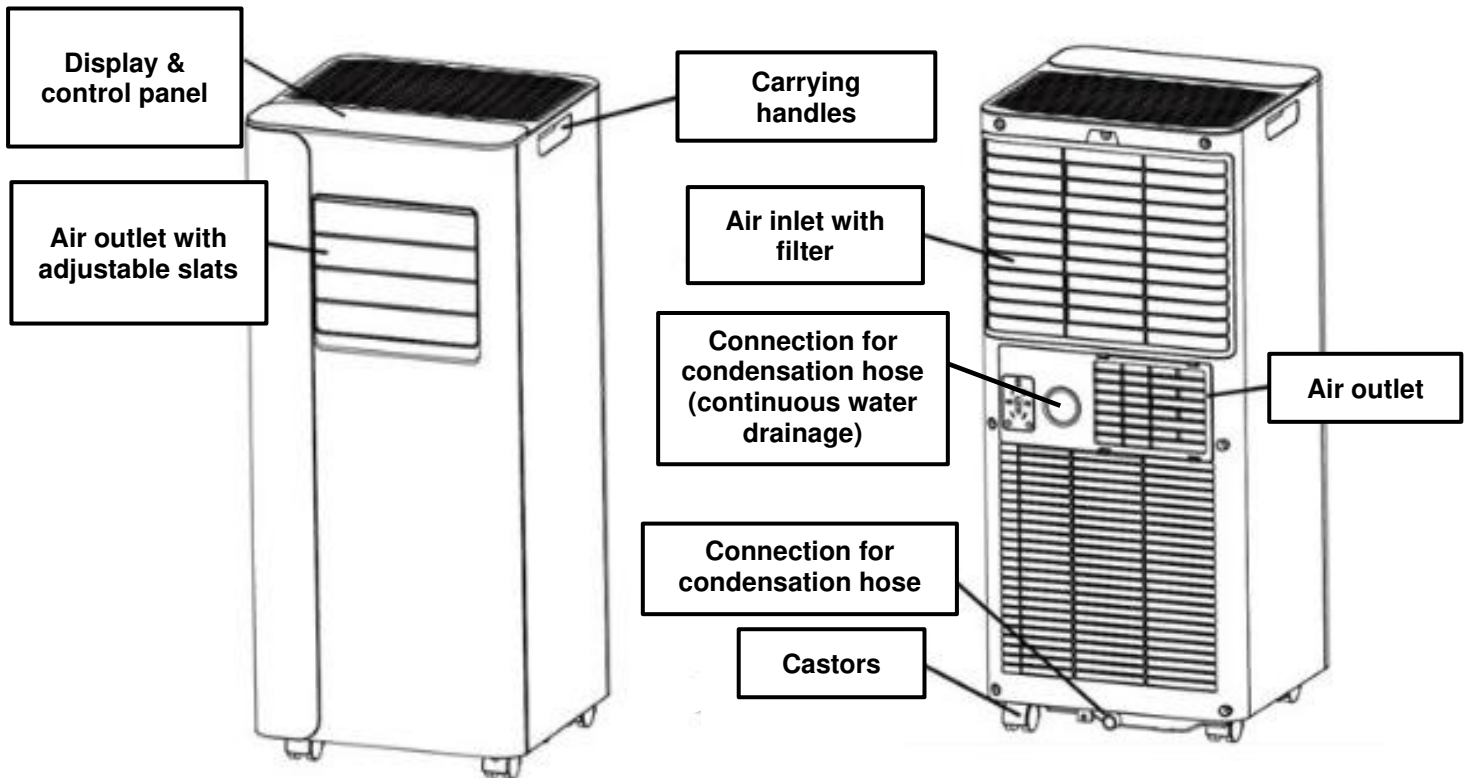

Operating recommendations:

For good cooling results and the most effective and economical operation possible, we recommend the following:

- We recommend this air conditioner for rooms up to 18 m² (43 m³) in size!
- The minimum size of the room in which the unit is operated should exceed 9 m²!
- Close doors and windows.
- Avoid direct sunlight entering the room through doors and windows. It is best to close the shutters or curtains during the day.
- Always keep the air filter of the air conditioner clean.
- If the temperature has fallen below the desired room temperature by at least 1 °C, the compressor switches off automatically.

Product features and characteristics:

- High capacity in a compact size with ventilation, cooling, and dehumidifying functions.
- Temperature setting and display
- LED digital display
- Electronic control with integrated timer
- Sleep mode
- Self-evaporation system for greater efficiency
- Automatic shut-off when tank is full
- Automatic restart after power failure
- Automatic defrost function at low ambient temperatures
- Remote control
- Castors: Allow the air conditioner to be easily moved from room to room.

Accessories:

1. Exhaust air hose
2. Hose connection
3. Adapter for the window sealing
4. Remote control
5. Condensation hose
6. Window sealing
7. Operating instructions (not shown)

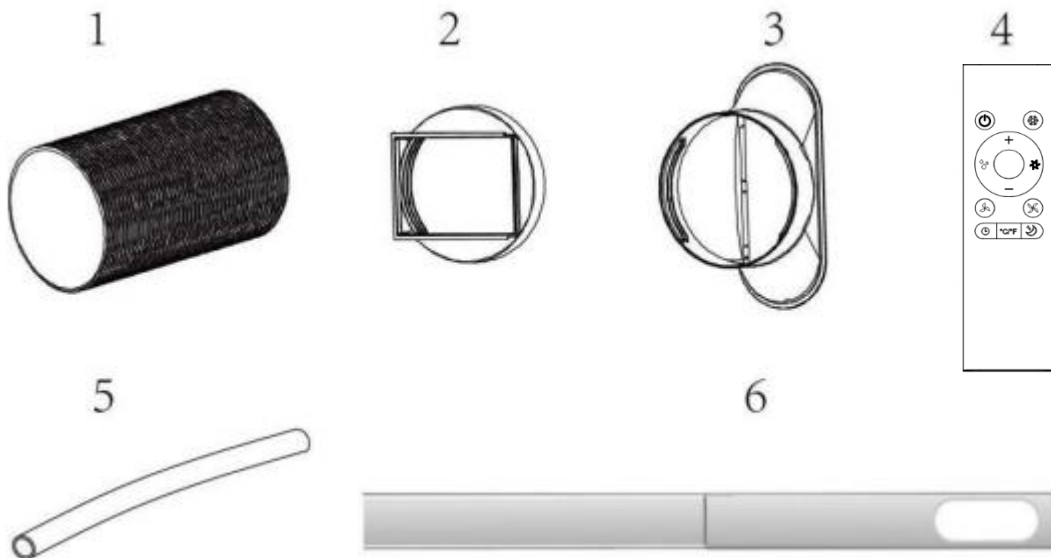

1. Setting up the device and connecting the window sealing:

The mobile air conditioner generates warm exhaust air during cooling. This warm exhaust air must be discharged to the outside. You can either discharge the warm exhaust air to the outside through a suitable hole (152 mm diameter) in the wall (similar to a kitchen extractor hood) or through a gap in an open window/door.

Note: Depending on the conditions, it may be advantageous to use the window sealing supplied for this purpose. This is variably adjustable and can ensure that no air from outside enters the room.

1.1. Connecting the exhaust hose for warm air

Note:

The air conditioner must be vented to the outside so that the exhaust air - with waste heat and moisture - actually leaves the room. Do not modify or extend the exhaust hose! This will result in poorer performance or, in the worst case, the device will shut down because too much back pressure builds up in the hose.

1.2. Connect the hose connection to one end of the exhaust hose.

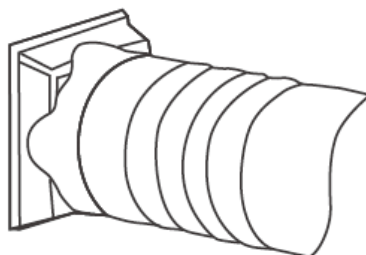

1.3. Connect the window sealing adapter to the other end of the exhaust hose.

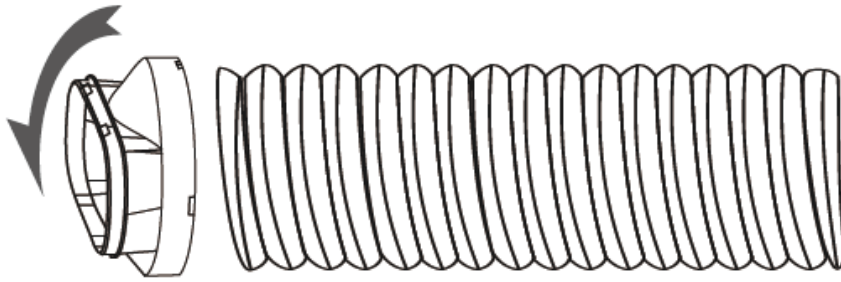

1.4. Extend the adjustable window sealing to match the width of your window. Then connect the exhaust hose to it.



1.5. Close your window to secure the window sealing. Make sure that the window sealing is tight - seal with tape if necessary. For maximum efficiency, you should also seal any gaps between the sealing and the window frame.

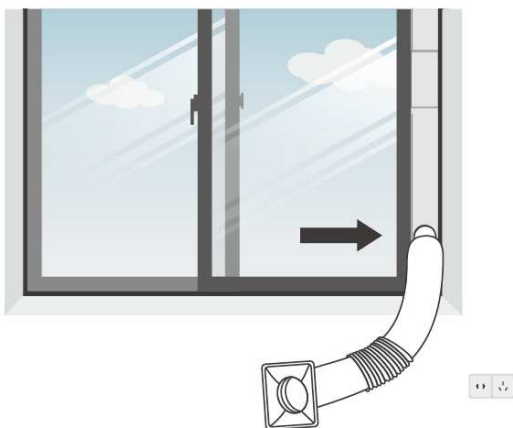

1.6. Plug the hose connection into the exhaust vent of the device.

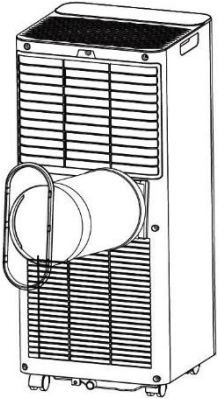

1.7. Adjust the length of the flexible exhaust hose and avoid kinks in the hose. Then place the air conditioner near a power outlet.

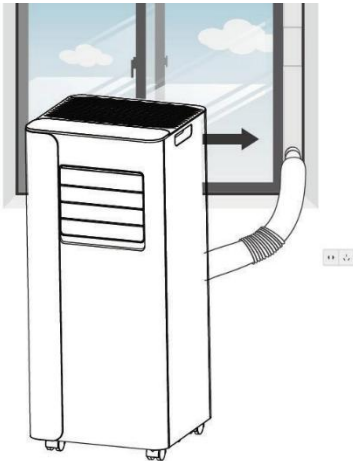

Warning:

The length of the exhaust hose is specifically designed for the specifications of this air conditioner. Please do not replace the exhaust hose with another one and do not attempt to extend it. This can lead to damage or reduce the performance of your device!

- Always use only suitable accessories for connecting and discharging the warm air!
- The exhaust air hose must never be kinked or obstructed (see adjacent illustration)! Otherwise, this may lead to overheating of the unit, resulting in shutdown and/or even damage to your air conditioner!
- The exhaust air hose can be extended from 25 cm to a maximum of 160 cm. However, for maximum effectiveness and economy, we recommend using the shortest length possible!

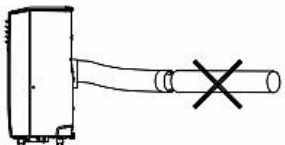
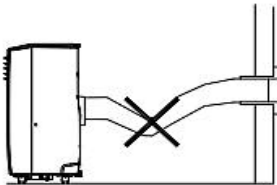
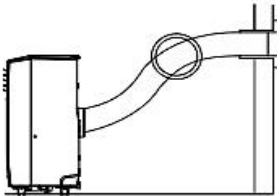
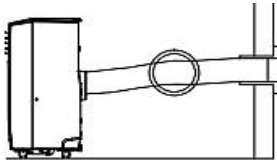

2. Function description of the control panel:

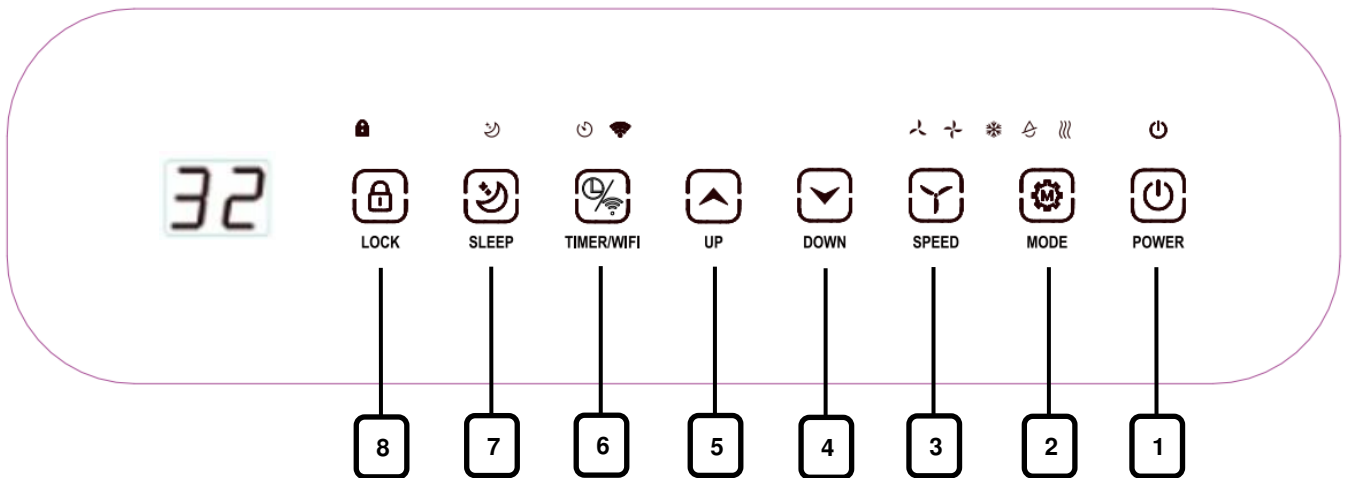

1	ON/OFF switch	5	UP: Button for adjusting the temperature or timer upwards
2	Mode button - Cooling mode - Dehumidification mode - Ventilation mode	6	<u>Timer button</u> (from 01-24) <u>WiFi button</u> : Press and hold the button to start the WiFi pairing function.
3	Setting the fan speed (low/high)	7	Sleep mode
4	DOWN: Button for lowering the temperature or timer setting	8	Child lock

3. Remote control:

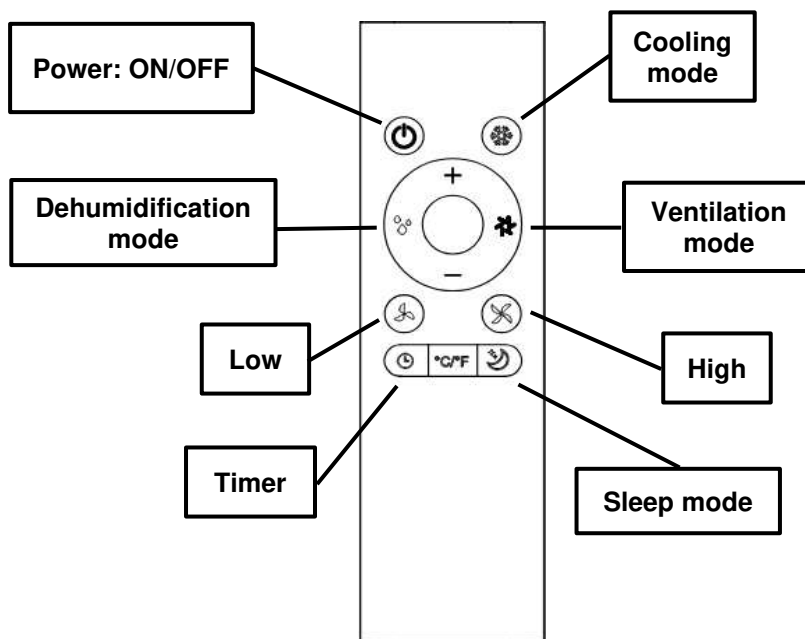

Instruction manual:

1. Start-up

- Plug the power cord into the power outlet correctly.
- Check that the exhaust hose for warm exhaust air is installed correctly (see pages 10-12 of this user manual).
- Ensure that the horizontally mounted outlet louvers are open in the desired direction.
- Press the ON/OFF switch to turn on the device. 
- The air conditioner will turn on and start in the last selected operating mode with the last selected settings. At the same time, the operating/signal lights will turn on. (Note: The room temperature display can show values from 0°C to 50°C.)
- The default target temperature in cooling mode is 23°C.

2. Selecting the operating mode

Press the MODE button to select the desired operating mode:

 = Cooling mode

 = Dehumidification mode

 = Fan mode

Note: The currently set operating mode is indicated by a small signal light above the mode button. The unit always starts with the last selected settings.

Note: By pressing and holding the mode button, you can change the temperature display unit from Celsius to Fahrenheit and back again.

3. Setting the target temperature

If you are operating the device in cooling mode, you can set the target temperature using the UP and DOWN buttons. Increase the temperature with the UP button and decrease the target temperature accordingly with the DOWN button. Adjust the temperature until the desired temperature is shown on the display.

The set target temperature will flash a few times and then remain lit. The desired target temperature is now set.

Note: You can set your target temperature between 16°C and 32°C!

Note: Please note that in cooling mode, the set target temperature is always shown, while in dehumidification mode and fan mode, the current room temperature is shown on the display.

4. Setting the fan speed

Press the fan button to set the desired fan speed:

 = High operating power

 = Low operating power

Note: The currently set operating speed is indicated by a small signal light above the button.

Note: Fan mode can only be operated at the lower fan speed.

5. Setting the timer function

If you want to activate/use the timer function (function for determining the remaining running time or function for specifying a start time), press the timer button.

You can activate or set the timer both in operating mode and in switched-off mode.

Determining the remaining running time in operating mode: Press the TIMER button to select the desired remaining running time using the UP or DOWN button. After this selected operating time has elapsed, the device switches off automatically after 20 seconds.

Setting a start time in off mode: When the air conditioner is switched off, press the timer button to select the desired start time. You can select a value between 01 and 24 hours using the UP or DOWN button. After this selected duration has elapsed, the device switches on automatically (with the last settings used and provided that the power plug has not been disconnected in the meantime).

Note: The remaining time until the device starts can be displayed by simply pressing the timer button again. Pressing the button again deactivates the set timer. The illuminated timer symbol goes out.

6. Connection with Tuya/WiFi

To activate the WiFi pairing function, press and hold the timer button for several seconds. The WiFi light will start flashing. You can now pair the device with the Tuya app. To do this, proceed as follows:

First, download the "Tuya Smart" app from the app store onto your smartphone or tablet. After downloading, open the app and make sure that your smartphone is connected to your WiFi network and that the Bluetooth function on your smartphone is turned on. Now follow the instructions in the app to register. After registering in the app, tap on "Add device." Select the "Air conditioner (WiFi)" button under the "Large household appliance" category. The air conditioner should now be displayed.

Tap on it to connect the device to your smartphone via the app. Once your smartphone is paired with the air conditioner, the WiFi function indicator light on the display will stop flashing and remain lit.

You can now conveniently adjust the air conditioner via the app and at the same time read values such as the current room temperature without having to stand directly in front of the device.

Note: If you do not use the WiFi function for a long time or do not pair the air conditioner with a WiFi network, this function switches to standby mode and the signal light stops flashing. To reactivate the WiFi pairing function, you must switch off the device and then press and hold the timer button for 5 seconds until a tone confirms activation. The signal light will now start flashing again. The WiFi pairing function is active again.

7. Activating sleep mode

Press the SLEEP button to activate sleep mode. **Note:** Sleep mode is only available in cooling mode.

In sleep mode, the target temperature is automatically increased by 1 °C during the first hour. In the second hour, the target temperature is automatically increased by another 1 °C. After that, the target temperature is maintained at this level.

Furthermore, the device always runs at the low fan speed in sleep mode.

Pressing the SLEEP button again deactivates sleep mode and reactivates the last selected settings.

Note: After 12 hours of operation in sleep mode, the air conditioner switches off automatically. After switching off the device and switching it back on again, sleep mode is not automatically reactivated; instead, the device starts up with the previously selected settings.

8. Manual water drainage

The unit has a self-evaporating system that uses the condensation collected during operation to cool the condenser coils, which improves energy efficiency.

During cooling operation, it is usually not necessary to drain the water manually, except in cases of very high humidity or in drying mode. The condensation evaporates at the condenser and is discharged to the outside via the exhaust hose.

However, if the condensate tray is full (display shows "Ft"), please proceed as follows:

1. As soon as the machine stops because the water tank is full, please unplug the power cord.
2. Move the appliance carefully to avoid spilling water from the bottom tray.
3. Place a suitable container under the side water drain at the rear of the appliance.
4. Remove the plug: the water will automatically run into the container.

Notes:

- Keep the plug in a safe place.
 - Tilt the appliance slightly backward during the drainage process.
 - If the container cannot hold all the water, replace the plug immediately once it is full to prevent overflow onto the floor or carpet.
5. Once the water has been drained, replace the plug.

Note: Only start the air conditioner after the plug has been installed correctly. Otherwise, condensation water could get onto the floor or carpet.

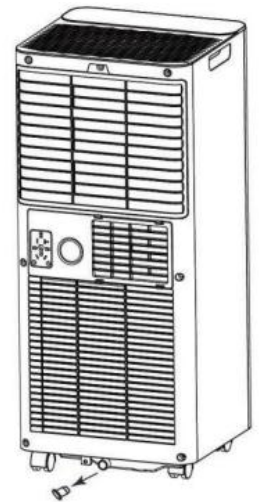

9. Continuous water drainage

For continuous operation or unattended operation in dehumidification mode:

Please connect the supplied drain hose to the unit.
This allows the condensation to drain automatically into a bucket or drain by gravity.

Proceed as follows:

1. Switch off the appliance before connecting the hose.
2. Remove the plug from the water drain and keep it in a safe place.
3. Connect the drain hose securely and correctly. Make sure that the hose is not kinked and that there are no blockages.
4. Place the end of the hose over a suitable drain or bucket so that the water can drain freely.
5. Do not immerse the end of the hose in water, as this can cause air to become trapped in the hose.



To prevent water leakage:

As negative pressure can build up in the water tank, the drain hose should be laid at a downward angle. A gradient of at least 20 degrees is recommended.

Avoid hose loops or differences in height where water could accumulate in- the hose should run as straight as possible.

10. Filter cleaning

During operation, dust collects in the filter and gradually reduces the air flow. Restricted air flow reduces the efficiency of the system and can cause damage if completely blocked. Therefore, the air filter must be cleaned regularly. The filter can be removed for this purpose. However, do not operate the device without an air filter, as this may contaminate the evaporator.

1. Switch off the device: Press the ON/OFF button to switch off the device and unplug the power cord.
2. Remove the filter: Remove the filter from the device.
3. Vacuum the dust: Use a vacuum cleaner to remove dust from the filter. Use the lowest setting to avoid damaging the filter.
4. Rinse the filter: Turn the filter over and rinse it under running water. Allow the water to run through the filter in the opposite direction of the air flow.
5. Dry: Allow the filter to air dry completely before reinserting it.

Note: Regular cleaning of the air filter ensures better air quality and higher efficiency of the device. Frequent cleaning may be necessary in case of heavy dust accumulation or frequent use.

Troubleshooting:

The device does not turn on/does not work:

- Check the power supply: Make sure the power cord is firmly plugged into the outlet.
- Check the water level: Is the water level indicator lit (display shows "Ft")? If so, remove the rubber plug and empty the drip tray.
- Check the room temperature: The device only works in a temperature range of 5°C to 35°C.

The device is not cooling sufficiently/is operating at reduced power:

- Check whether the room temperature is already below the selected target temperature.
- Check the air filter and clean it if necessary.
- Check whether the air ducts are blocked. Remove any obstacles.
- Close doors and windows: Make sure that doors and windows in the room are closed.
- Check the operating mode and temperature: Is the correct mode selected and the temperature set appropriately? Set both according to the operating instructions.
- Check whether the exhaust air hose is installed correctly. Make sure that the exhaust air hose is securely attached.

The device seems too loud/makes a lot of noise:

- Check the surface: Is the device standing upright and on a firm surface? Reposition it if necessary.
- Loose parts: Check whether any parts are vibrating or loose and tighten them if necessary.
- Water-like noises: These are caused by the circulating refrigerant - this is normal and no cause for concern.

Water leaks

- Water overflowing when moving: The water tank should be completely emptied before transport.
- Check the drain hose: Is the hose kinked or bent? Straighten it so that the water can drain freely.

List of all error codes:

Error code	Description	Solution
E0	Communication error between main board and display	Please turn off the device and contact a specialist.
E1	Ambient temperature sensor error	Have the ambient temperature sensor replaced by a specialist.
E	Error in the temperature sensor on the evaporator coil	Have the temperature sensor replaced by a specialist.
Ft	Water level indicator: Condensate tray full	Empty the condensate tray.

In the event of a defect, do not attempt to repair the air conditioner yourself!

Storing the air conditioner:

- Empty any condensation water from the condensate tray.
- Run the unit in fan mode for a few hours to allow it to dry completely inside.
- Remove the mounted exhaust hose.
- Clean the filters.
- Return the filter to its original position.
- Store the device in its original box.

Caution:

The evaporator inside the air conditioner must be completely dry before packing to prevent damage to components and mould growth. Unplug the device and place it in a dry, well-ventilated area. It should be left there for several days until it is completely dry.

Alternatively, you can switch on the device, set it to fan mode, and leave it running until the air outlet is dry. This will keep the inside of the device dry and prevent mould from forming.

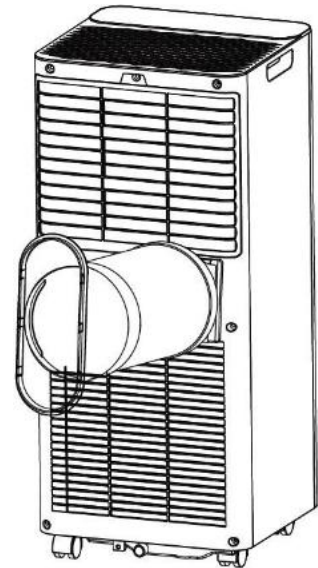

Technical data:

Model name:	WDH-AC016
Energy efficiency class (EER):	A
Energy consumption per hour according to EER:	1.005 kW/h
Cooling capacity:	9,000 BTU/h (2,637 watts)
Energy efficiency rating (EER):	2.62
Device type:	Cooling, dehumidification, fan
Cooling type:	Air cooling
Noise level:	Lowest setting: 54 dB(A), Highest setting: 56 dB(A)
Voltage:	220-240V ~ 50Hz
Max. power consumption:	1,005 W (4.5 A)
Power consumption during operation "Temperature controller off" (PTO):	1,005 W
Power consumption in standby mode (PSB):	Without WiFi function: 0.5 W; with WiFi function: 2.00 W
Electricity consumption (QSD):	1.003 kWh/a
Air circulation:	340 m ³ /h
Dehumidification capacity:	24 liters/day
Area of application:	12-18 m ²
Compressor:	Rotary compressor
Refrigerant:	R290 (180 g)
Dimensions (H/W/D):	289.5 x 303 x 673 mm
Dimensions of warm air duct:	Ø 150 x 1500 mm
Intake pressure:	0.7 MPa
Discharge pressure:	3.2 MPa
Protection class:	IPX1
Protection class:	I
Weight:	22 kg
Max. transmission power:	18.2 dBm
Frequency range:	2,400-2,484 MHz
Frequency band:	2.4 GHz (WLAN) with: < 20 dBm transmission power

The above data has been determined in accordance with EU standard EN 14511 and EU safety and testing regulations EN 60335-2-40.

COOLING - Dry temperature = 35°C; Wet temperature = 24°C

Fuse: T4AL250V

Other:

Warranty statement:

Notwithstanding the statutory warranty claims, the manufacturer grants a warranty in accordance with the laws of your country, but at least 1 year (in Germany 2 years for private individuals). The warranty period begins on the date of sale of the device to the end consumer.

The warranty covers only defects attributable to material or manufacturing faults.

Warranty repairs may only be carried out by an authorized customer service center. To claim your warranty, please enclose the original sales receipt (with date of sale).

The following are excluded from the warranty:

- Normal wear and tear
- Improper use, such as overloading the device or using unauthorized accessories
- Damage caused by external influences, use of force, or foreign objects
- Damage caused by failure to follow the operating instructions, e.g. connection to the wrong mains voltage or failure to follow the installation instructions
- Devices that have been completely or partially dismantled

Conformity:

The air conditioner has been tested and manufactured in accordance with the following (safety) standards:

TÜV Süd GS-tested and, of course, CE (EMC + LVD) compliant.

Safety tested in accordance with: EN 60335-1:2012/A16:2023
EN 60335-2-40:2003/A13:2012
EN 62233:2008
AfPS GS 2019:01 PAH
EK1 527-12 Rev. 2

CE (LVD) conformity tested according to: EN 60335-1:2012/A16:2023
EN 60335-2-40:2003/A13:2012
EN 62233:2008

CE (EMC) compliance tested according to: EN IEC 55014-1:2021
EN IEC 55014-2:2021
EN IEC 61000-3-2:2019/A2:2024
EN 61000-3-3:2013/A2:2021

RED compliance tested according to: EN 301 489-1 V2.2.3:2019
EN 301 489-17 V3.3.1:2024
EN 300 328 V2.2.2:2019
EN 50663:2017
EN 62479:2010
EN 50665:2017
EN 62311:2008
EN 18031-1:2024

- Health and safety requirements pursuant to article 3.1 a)
Health and safety requirements pursuant to Article 3.1 a)
- Electromagnetic compatibility, Article 3.1 b)
Electromagnetic compatibility § 3(1)(2), Article 3.1 b)
- Efficient use of the radio frequency spectrum Article 3.2
Efficient use of the radio frequency spectrum Article 3.2
- Network protection pursuant to Article 3.3 d)
Protection of Network pursuant to article 3.3 d)

Proper disposal of this product:



Within the EU, this symbol indicates that this product must not be disposed of with household waste. Old devices contain valuable recyclable materials that should be recycled and should not be disposed of in an uncontrolled manner, as this could harm the environment or human health. Therefore, please dispose of old devices via appropriate collection systems or send the device to the place where you purchased it for disposal. They will then recycle the device.



We hope you enjoy using this device.

Aktobis AG

Keep these instructions in a safe place!

